

# Orten'zia, petals of *light*.

design Bruno Rainaldi  
terzani.com

**TERZANI**  
LA LUCE PENSATA





**Product Name**  
Orten'zia  
small pendant light

**Materials**  
metal



**Finishes | Code**

-  nickel  
OM46S E7 C8
-  gold  
OM46S H8 C8

**Body**

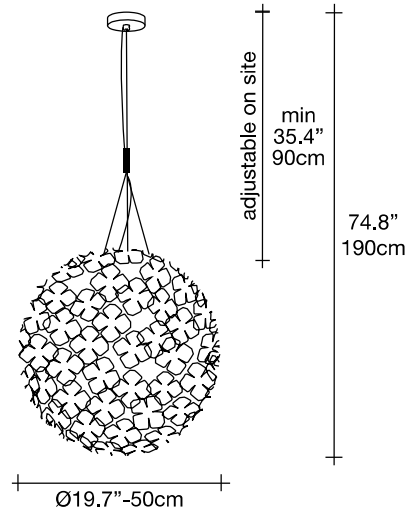

**Recommended Light**  
120V ~ 50/60Hz

 LED  
15W E26

dimmable with

 all systems

**Canopy**

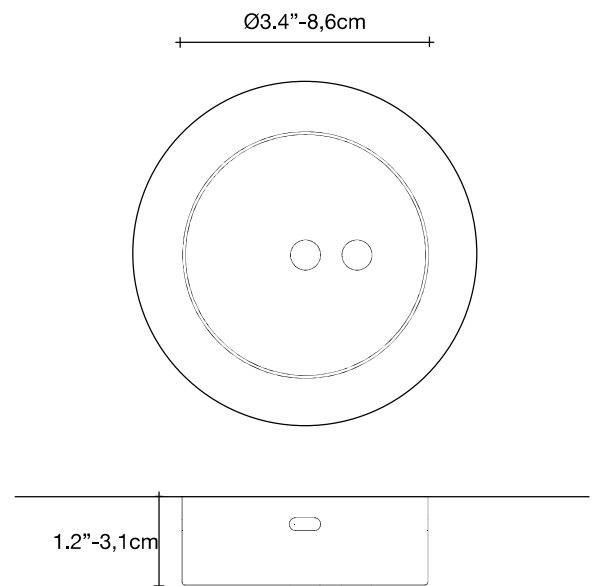

Recalling the natural beauty of a flower, Orten'zia hand-soldered "petals" emanate a unique glow, immersing the entire room in a glimmering light. An organic radiance is created through light and shadow, planting a garden within the room. Available in either nickel or gold plated, the orten'zia's elegant form complements its dramatic light. Design Bruno Rainaldi.

# Orten'zia, petals of *light*.

design Bruno Rainaldi  
terzani.com

**TERZANI**  
LA LUCE PENSATA





**Product Name**  
Orten'zia  
large pendant light

**Materials**  
metal



**Finishes | Code**

-  nickel  
OM51S E7 C8
-  gold  
OM51S H8 C8

**Body**

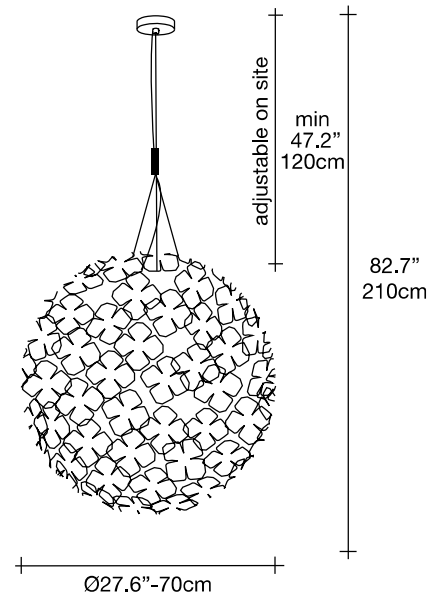

**Recommended Light**  
120V ~ 50/60Hz

 LED  
15W E26

dimnable with

 all systems

**Canopy**

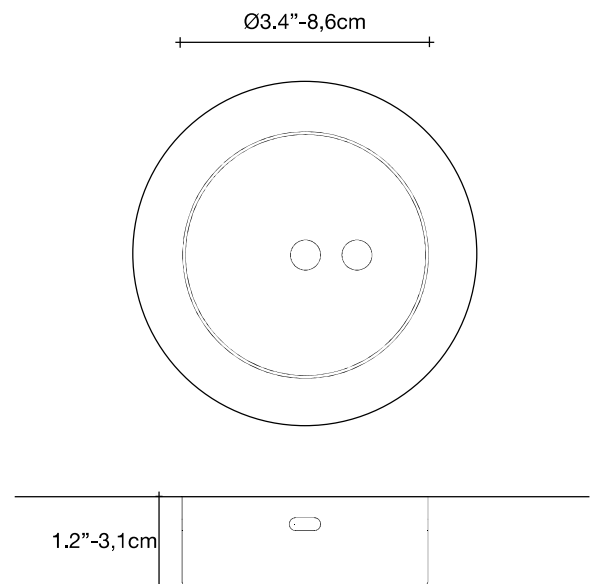

Recalling the natural beauty of a flower, Orten'zia hand-soldered "petals" emanate a unique glow, immersing the entire room in a glimmering light. An organic radiance is created through light and shadow, planting a garden within the room. Available in either nickel or gold plated, the orten'zia's elegant form complements its dramatic light. Design Bruno Rainaldi.